

DESIGNING AN ECO-FRIENDLY ASSEMBLY FOR ENHANCED PORTABILITY OF A CUSTOM LASER-INDUCED FLUORESCENCE SYSTEM

Maria – Andreea PĂTRAȘCU¹*, Georgiana CHIȘIU²*

This paper presents the design of an environmentally friendly assembly aimed at optimizing the transportation and in-situ operation of a custom laser-induced fluorescence (LIF) system developed by INOE 2000. Currently the system performs optimally under laboratory conditions, but it faces limitations for in-situ operation. However, given that LIF is a non-destructive technique with significant potential for remote in-situ analysis, expanding its usability for field-based applications is crucial. To enable seamless transport and operation both inside and outside the laboratory, an assembly was specifically designed to incorporate the LIF system's optical and optomechanical components, housed in customized enclosures designed for efficiency and protection.

Keywords: design engineering, laser-induced fluorescence, custom systems, portability, heritage science

1. Introduction

Laser-induced fluorescence (LIF) is an optical spectroscopy method where a sample is excited by a laser, and the resulting fluorescence emitted from the sample is recorded by a photodetector [1]. This technique allows for sensitive detection and analysis of various materials by measuring the specific wavelengths of light emitted during the fluorescence process.

The principle behind LIF relies on the interaction between laser radiation and matter at the molecular level. When laser radiation interacts with matter, particles may absorb photons and transition into an excited energy state. From this state, they tend to return to their ground state, a process that triggers fluorescence [1], [2]. Fluorescence emission occurs at wavelengths longer than the excitation wavelength (usually in the visible).

The diagram shown in Figure 1 (adapted from [3]) illustrates the main phenomena that occur when electromagnetic radiation interacts with matter: absorption, fluorescence and phosphorescence. Molecules can

¹ * Corresponding author, Eng., Dep. of Optoelectronic Methods and Techniques for Artwork Restoration and Conservation, National Institute for Research and Development in Optoelectronics - INOE 2000, Romania, e-mail: andreea.patrascu@inoe.ro

²* Reader, Dept. of Machine Components and Tribology, National University of Science and Technology POLITEHNICA Bucharest, Romania, e-mail: georgiana.chisui@upb.ro

exist in singlet (S) or triplet (T) electronic energy states, depending on the spin orientation of the electrons, each of which has several vibrational and rotational energy levels. Prior to interaction with an electromagnetic wave, the molecule is in its ground state, usually the singlet state. By absorbing a photon, a molecule is excited from a singlet ground state (S_0) to a singlet excited state (S_1) on a higher vibrational level. From here, the molecule will return to the ground state, which means it will lose energy. This can be achieved by radiative and/or non-radiative pathways [1], [2].

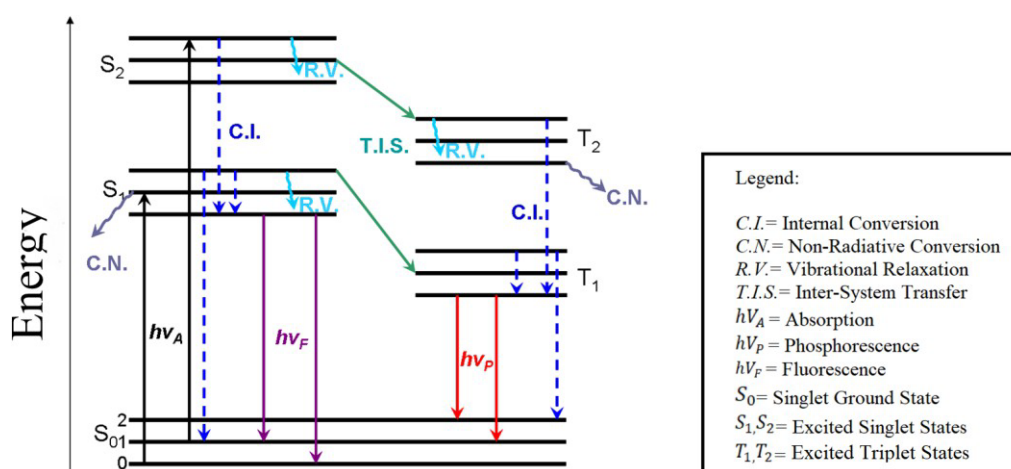

Fig. 1. Jablonski diagram

Fluorescence is a short-lived phenomenon composed of three successive phases: energy absorption or excitation, quiescence in the excited state and luminescent emission. Each phase has a variable duration in time, which depends on the structure and nature of the substance being analyzed. Practically, the most important phase is the emission one. The duration of a luminescent emission is assessed by determining the extinction time, the time that elapses from the cessation of excitation until the emission can still be observed. Experimentally, one determines the time during which the emission intensity, considered to be the maximum at the moment of cessation of excitation, decreases to $1/e$ or $1/10$ of this value. The fluorescence emission maximum, for a given material, occurs only for a given excitation wavelength. The value of the intensity depends on the intrinsic properties of the compound and on experimental parameters, including the intensity of incident radiation and the concentration of fluorophores [1], [2].

In 1968, Richard Zare pioneered the first successful LIF experiments on the potassium dimer molecule, marking a significant advancement in spectroscopy and fluorescence analysis [4], [5]. Since then, LIF has found applications across

diverse fields, including medicine, biochemistry, biophysics, materials science, environmental research, or cultural heritage [6], [7], [8].

Within the heritage science field, LIF has been successfully applied to the study of a wide range of materials associated with works of art, such as: stone and minerals, pigments and colorants, organic binding media. Biological attack as well as trace of former restorations were also investigated by laser-induced fluorescence [8].

Material characterization and identification in heritage and conservation science constitute a well-established research field that demands high-performance, non-invasive, non-destructive, and portable instruments [9], [10]. In this context, laser-induced fluorescence spectroscopy (LIF) stands out as a promising analytical technique, offering unique advantages for heritage applications: high sensitivity and selectivity, high spatial resolution, versatility and minimal sample interference. Furthermore, LIF is a non-invasive, non-contact technique that can be used remotely, both in the laboratory and *in-situ*, without requiring sampling or surface preparation.

In the field of heritage science, equipment portability is crucial [11]. Mobile heritage objects can often be transported to a laboratory for detailed analysis, enabling examination under controlled environmental conditions [12], [13]. However, immobile heritage objects, such as those *in-situ* at archaeological sites or within museums, cannot be moved [14]. This limitation underscores the importance of developing portable non-invasive analytical tools that can deliver high-quality results without the need to relocate the objects.

Portable LIF systems are particularly well-suited for remote locations or situations where sampling is not possible. Despite its numerous advantages and strengths, LIF is still relatively underutilized compared to other analytical techniques, mainly because of the limited availability of commercial equipment. Currently, the majority of reported applications in the field have been achieved using in-house developed LIF systems [15], [16]. These systems are primarily designed for remote investigations and incorporate complementary features in order to be able to provide fast and as accurate results for artworks of various sizes and in different locations, extending beyond traditional laboratory settings.

2. The custom LIF system developed by INOE

The first LIF system was developed at National Institute for Research and Development in Optoelectronics - INOE 2000 between 2006 and 2008 as a portable laser scanning device for polychrome artwork surface investigation. The system was designed to generate intensity distribution maps for different LIF spectrum peaks, obtained by scanning the investigated surface. A first national patent was granted in 2009 [17], and the LIF system was immediately implemented in several studies [16], [18]. The concept was further developed, mainly due to the fact that all the elements were custom build, including the control software. One of the main upgrades was the implementation of a remote operation capability (teleoperation), via the internet [19]. The development was a novel achievement for Romanian scientific community. Using LabView webserver features, a protocol was designed so that the software user interface could be accessible via a local server and an HTML page, in a web browser, from anywhere in the world. This upgrade required several hardware adjustments including a video live feed of the scanned area. The control and feedback were in real-time. This upgraded system was also patented at national level in 2012 [20].

The developed LIF scanning system has been successfully used both in the laboratory and during various field campaigns, including within notable sites in Romania such as Tismana Monastery or the Painted Hypogeum Tomb in Tomis (Constanța). Additionally, the system has been showcased in several workshops and demonstration exhibitions, in sites such as the Roman Mosaic Edifice in Constanța, or St. Stephen Church in Nessebar (Bulgaria). These applications underscore the system's versatility and effectiveness in both controlled and on-site environments, highlighting its value in cultural heritage preservation and research. A third patent was obtained in 2014 [21] along with multiple awards, including a gold medal at international invention and innovation fairs, recognizing the innovative applications of the LIF system in the cultural heritage sector.

Starting with 2022, within the frame of the artMAP project [22], the LIF system underwent significant upgrades. These upgrades included the incorporation of a new ultra-compact Q-Switched Nd:YAG laser source with multiple wavelengths in the UV region (355 nm and 266 nm), along with the replacement of several other optical and optomechanical components related to the scanning system. The objective of these upgrades was to develop a state-of-the-art system capable of expanding the range of applications for laser-induced fluorescence spectroscopy, thereby enhancing its effectiveness in various research and conservation contexts.

Figure 2 shows the schematic of the upgraded LIF scanning system. A UV laser beam is emitted from the source L, collimated by the collimating lens CL, penetrates through the aperture of the perforated mirror Mp and is finally retransmitted by a duo-axial galvanometer (G) to the area of interest of the investigated surface. The galvanometer is controlled via USB port by the user through the CU central unit. Upon interaction of the laser beam with the material surface, fluorescence in the visible range is emitted in all directions. The FL optical collector is focused to capture the area where fluorescence is produced. This is achieved by means of a coaxial system consisting of M, MF and galvanometer mirrors. The captured fluorescence is filtered by the optical filter F before being transmitted through the optical fiber OF to the spectrometer S. The spectrometer encodes the optical information into digital information and transmits it to the CU where, by means of acquisition software, it is displayed as a spectrum. The CU has software applications to control and synchronize the repositioning of the galvanometer motor G with the laser pulse emission and acquisition time of the spectrometer S.

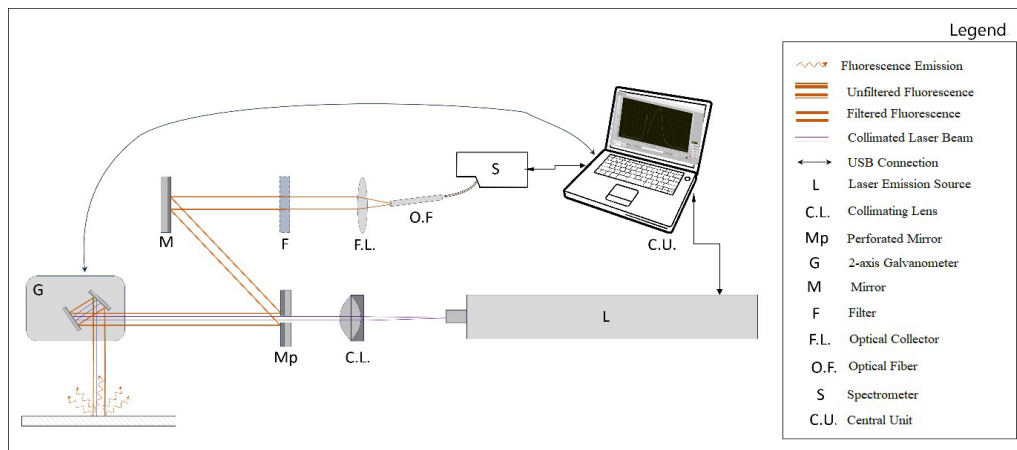

Fig. 2. Schematic drawing of the upgraded LIF system

As shown in Figure 2, the recently upgraded LIF system comprises a significant number of optical and optomechanical components, and while *in-situ* mobility is a goal, its current setup design necessitates disassembly and recalibration when transitioning between laboratory and field environments. This process can be time-consuming and may impact the efficiency of field operations, limiting the system's potential for rapid deployment. As previously highlighted, streamlining the transition process is crucial for improving the system's adaptability and optimizing its use across various research scenarios.

To address this need, an environmentally friendly assembly was designed specifically to facilitate the transportation of the LIF system. This assembly not only allows for efficient storage and transport but also ensures that the equipment can be operated seamlessly in both laboratory and field settings. By eliminating the need for frequent equipment swapping, this design enhances operational efficiency and enables researchers to deploy the LIF system more effectively. Not least, this streamlined approach aims to maximize the system's potential in various applications.

Table 1

Main subsystem components of the upgraded LIF scanning system

Components	Dimensions W x H x L mm
Laser power supply unit	200 x 430 x 380
Laser head (1064 nm only)	82 x 62 x 282
Attenuator module	82 x 62 x 74
Modular harmonic generation unit	82 x 62 x 290
Spectrometer	115 x 50 x 185
Fiber optic collector	26 x 26 x 120
Duo-axial galvanometric scanning system	60 x 35 x 80
Data acquisition device	90 x 35 x 130
Linear power supply	180 x 120 x 280
Full HD micro camera	40 x 44 x 55

The material selected for the transportation assembly is acrylonitrile butadiene-styrene (ABS), primarily chosen for its exceptional thermal stability [23]. In addition to its robust physical properties, ABS also offers several environmental advantages that align with the European Union's directives on promoting a greener environment [24]. ABS is a copolymer composed of three monomers: acrylonitrile, butadiene, and styrene. Acrylonitrile in ABS enhances the material's chemical and thermal stability, while butadiene imparts durability and strength. Additionally, styrene gives the polymer a smooth, glossy finish. When these monomers are combined, acrylonitrile forms polar bonds with butadiene and styrene, resulting in a remarkably strong and durable end product [25], [26]. This unique composition not only enhances the material's structural integrity but also provides excellent impact resistance and thermal stability, making ABS an ideal choice for protecting sensitive optical and optomechanical components during transport.

ABS features a low melting point, which facilitates its use in injection molding and 3D printing processes. Additionally, it also exhibits high tensile and physical impact strength as well as excellent resistance to chemical corrosion, making it suitable for heavy use and harsh

environmental conditions. ABS can be easily molded, sanded, and shaped, and its glossy surface is highly compatible with various paints and adhesives. This plastic material also absorbs colors effectively, allowing final products to be painted in precise shades that meet project specifications [27].

Furthermore, the lightweight nature of this copolymer enhances the overall portability of the LIF system, allowing for ease of handling in various environments. The durability of ABS ensures that the transportation assembly can withstand the rigors of fieldwork, thereby enhancing the longevity and reliability of the LIF system in diverse applications.

3. Assembly design

Careful consideration has been given to all components of the LIF system, taking into account their dimensions and space utilization to ensure they can be properly positioned for operation or easily removed for servicing or replacement when necessary. To enhance the mobility of the system, the assembly has been designed with practicality in mind. It features four wheels and two handles, allowing for effortless maneuvering across various environments. Additionally, an extension cord with eight sockets has been incorporated to provide ample power supply options, while a dedicated storage compartment within the assembly offers convenient space for essential accessories and tools.

The proposed assembly was designed using the Autodesk Inventor 3D CAD (Professional 2023) software.

The first step of the process involved the design of a shelf (Fig. 3) to support all components of the LIF system, incorporating brackets to secure them in place and prevent any shifting during operation or transport, thus providing protection against vibrations. The design facilitates the organization of equipment cables within a dedicated drawer, allowing for seamless connections to an extension cable for power supply. To accommodate this, a specific compartment has been allocated for the extension cable, ensuring it remains tidy and easily accessible. For connection to a power source, a small space has been created for the extension cable. Another circular space has been created for connecting the laser cable. For added safety during transport, spaces have been integrated at each of the four corners of the drawer, allowing for a lid to fit securely over the assembly. This thoughtful design enhances the protection of the equipment while in transit.

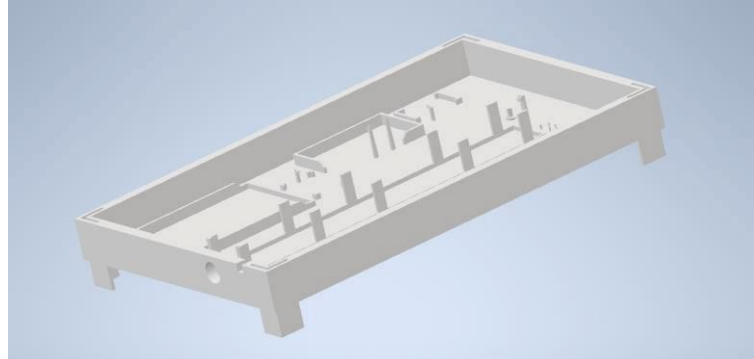

Fig. 3. Shelf component

One of the primary objectives of this project was to optimize space, resulting in a compact and efficient final product that can support all necessary components. Consequently, the dimensions of the drawer have been carefully crafted to measure 850 x 542 x 126 mm, with a thickness of 20 mm, striking a balance between space efficiency and structural integrity.

The next step involved designing the lower part of the assembly (Fig. 4), specifically intended for the secure storage of the laser power supply unit. To begin this phase, a housing structure was created, which was subsequently enhanced by adding protective walls and support feet to ensure stability. Consistent with the design employed for the shelf, four spaces were left in each corner of the housing to allow for the drawer to overlap securely. The dimensions of this compartment are 850 x 642 x 319.5 mm, with a thickness of 20 mm, providing ample space while maintaining a compact footprint.

The assembly was intended to be easy to handle for two people, but if there are times when it is operated by one person it should not be too difficult either. Figure 4 shows the lower part of the assembly, the storage area for the LPU, which is quite voluminous and requires standing when in use. No ventilation spaces have been created because for this assembly it was decided that the LPU would be positioned on the side for space saving, and when operating the entire LIF system it would be removed from the box and put into operation. In the future it is intended to modify the system to allow the LPU to be used without removing it from the storage space.

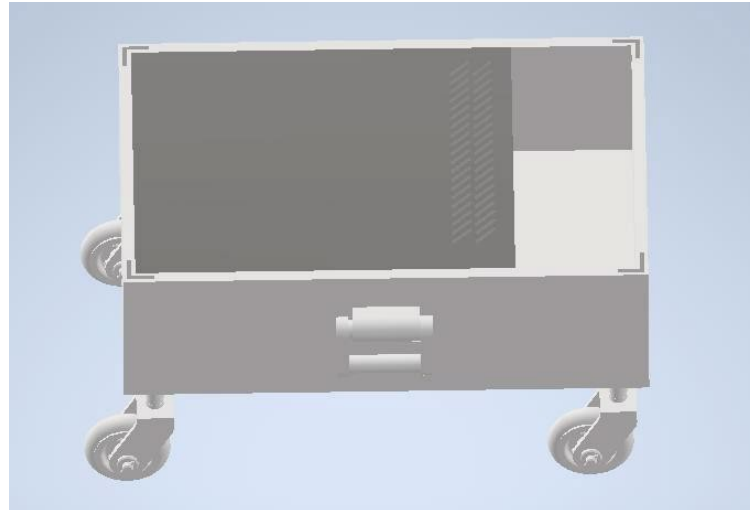

Fig. 4. Lower part with equipment and extra storage space

As previously mentioned, to facilitate the transportation process and enable the equipment to be utilized in the field, the assembly incorporates four wheels and two handles. The wheels have been designed with dimensions of 240

x 145 x 95 mm, while the handles measure 156 x 100 x 40 mm, ensuring ease of mobility without compromising structural integrity.

This design enhancement allows a single individual to maneuver the equipment efficiently, significantly reducing the time and effort required for relocation. It is worth noting that at present, using the equipment in outdoor settings presents considerable challenges, as it necessitates dismantling all components, securing them in a safe environment, and then reassembling and recalibrating the system upon arrival at the field site. Once the sample collection is complete, this entire process must be repeated to transport the equipment back to the laboratory. However, with the development of this specialized storage and usage box, the equipment can be transported and operated at any necessary location without the need for extensive setup or teardown procedures. This advancement not only enhances operational efficiency but also broadens the scope of potential applications for the LIF system in various field settings.

To ensure the protection of all the components, a cover (Fig. 5) has been designed to fully enclose the assembly. This cover is securely attached to the initial drawer using the previously mentioned fastening system. It has dimensions of 850 x 542 x 126 mm, providing a comprehensive shield against external elements and safeguarding the components during transport and storage.

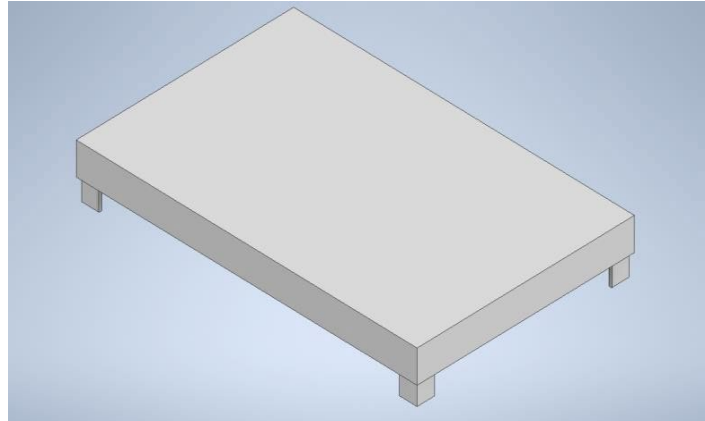

Fig. 5. Cover component

The final assembly (Fig. 6) of all the aforementioned components was conducted using the *Assembly function* in Autodesk Inventor 3D CAD software, which facilitated precise alignment and integration of each part to ensure that the entire system functions cohesively and efficiently.

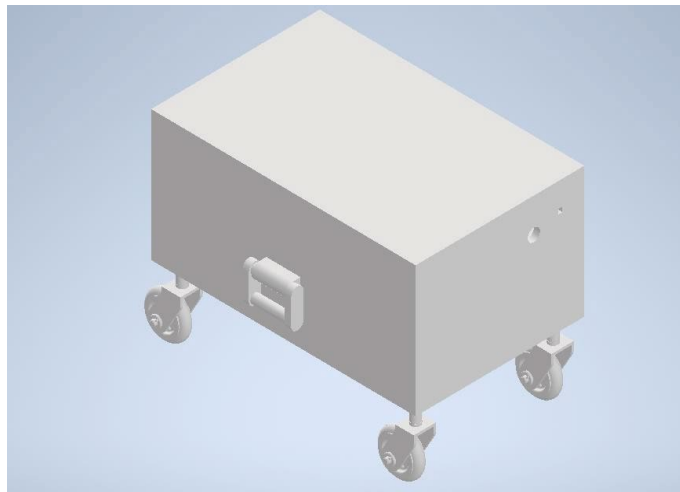

Fig. 6. Final designed assembly

4. Conclusions

This paper outlines the design of an environmentally friendly assembly that optimizes the operation and transportation of a custom laser-induced fluorescence (LIF) system developed by INOE 2000. The newly designed assembly enhances the system's portability, significantly improving its usability for in-situ and field-based applications, a crucial aspect given the non-destructive nature of the technique.

The selection of acrylonitrile butadiene-styrene (ABS) as a material for the transport assembly not only safeguards sensitive components but also supports environmental sustainability initiatives. ABS offers key advantages, including excellent impact resistance, high tensile strength, and thermal stability, making it ideal for protecting sensitive equipment during transit. Additionally, the incorporation of ergonomic features, including wheels and handles, enhances transportation efficiency, allowing a single user to operate the system with minimal effort.

Acknowledgements

This work was supported by a grant from the Ministry of Research, Innovation and Digitization, CCCDI—UEFISCDI, project number PN-III-P2-2.1- PED-2021-3576, within PNCDI III, and through the Core Program within the National Research Development and Innovation Plan 2022-2027, project no. PN 23 05.

REFERENCES

- [1] *J.R. Lakowicz*, Principles of Fluorescence Spectroscopy. 3rd Edition, Springer: New York, NY, USA, 2006.
- [2] *Jablonski, A.*, Über den Mechanismus der Photolumineszenz von Farbstoffphosphoren, Zeitschrift für Physik, 94(1–2), 38–46, 1935
- [3] *H.H. Telle, A. Gonzalez Urena, R.J. Donovan*, Laser-induced Fluorescence Spectroscopy. In Laser Chemistry: Spectroscopy, Dynamics and Applications; Chichester: West Sussex, UK, pp. 101–118, 2007.
- [4] *R.N. Zare*, My life with LIF: A personal account of developing laser-induced fluorescence, Annu. Rev. Anal. Chem., Vol. 5, 2012, DOI: 10.1146/annurev-anchem-062011-143148.
- [5] *W.J. Tango, J.K. Link, R.N. Zake*, Spectroscopy of K2 using laser-induced fluorescence, J. Chem. Phys., Vol. 49, Iss. 10, 1968, DOI: 10.1063/1.1669869.
- [6] *M. Kwaśny, A. Bombalska*, Applications of Laser-Induced Fluorescence in Medicine, Sensors, Vol. 22, Iss. 8, 2022, DOI: 10.3390/s22082956.
- [7] *A.T. Taylor, E.P.C. Lai*, Current State of Laser-Induced Fluorescence Spectroscopy for Designing Biochemical Sensors, Chemosensors, Vol. 9, Iss. 10, 2021, DOI: 10.3390/chemosensors9100275.
- [8] *L. Ghervase, I.M. Cortea*, Lighting Up the Heritage Sciences: The Past and Future of Laser- Induced Fluorescence Spectroscopy in the Field of Cultural Goods, Chemosensors. Vol. 11, Iss. 2, 2023, DOI: 10.3390/chemosensors11020100.
- [9] *J.M. Madariaga*, Analytical chemistry in the field of cultural heritage, Anal. Methods, Vol. 7, Iss. 12, 2015, DOI: 10.1039/C5AY00072F.
- [10] *B. Brunetti, C. Miliani, F. Rosi, B. Doherty, L. Monico, A. Romani, A. Sgamellotti*, Non- invasive investigations of paintings by portable instrumentation: The MOLAB experience, Top. Curr. Chem., Vol. 374, 2016, DOI: 10.1007/s41061-015-0008-9.
- [11] *F. Pozzi, A. Rizzo, E. Basso, E.M. Angelin, S. França de Sá, C. Cucci, P. Marcello*, Portable Spectroscopy for Cultural Heritage. In Portable Spectroscopy and Spectrometry II— Applications, 1st ed.; Crocombe, R.A., Leary, P.E., Kammrath, B.W., Eds.; Wiley, Hoboken, NJ, USA, Vol. 2, pp. 499–522, 2021.
- [12] *I.M. Cortea, L. Ratoiu, A. Chelmuş, T. Mureşan*, Unveiling the original layers and color palette of 18th century overpainted Transylvanian icons by combined X-ray radiography, hyperspectral imaging, and spectroscopic spot analysis, X-Ray

- Spectrom., Vol. **51**, Iss. 1, 2021, DOI: 10.1002/xrs.3249.
- [13] *I.M. Cortea, L. Ghervase, L. Ratoiu, O. Țentea, M. Dinu*, New Insights into the Materials and Painting Techniques of Ancient Wall Paintings from the Roman Province of Dacia: A Minimally Invasive Multi-Method Approach, *Heritage*, Vol. **7**, Iss. 9, 2024, DOI: 10.3390/heritage7090248.
- [14] *I.M. Cortea, L. Ghervase, L. Ratoiu, M. Dinu, R. Rădvan*, Uncovering hidden jewels: an investigation of the pictorial layers of an 18th-century Taskin harpsichord, *Herit. Sci.*, Vol. **8**, 2020, DOI: 10.1186/s40494-020-00401-3.
- [15] *M.F. Caso, L. Caneve, V. Spizzichino*, Improvement of ENEA laser-induced fluorescence prototypes: An intercalibration between a hyperspectral and a multispectral scanning system, *ACTA IMEKO*, Vol. **10**, Iss. 1, 2021, DOI: 10.21014/acta_imeko.v10i1.822.
- [16] *L. Angheluță, J. Striber, R. Rădvan, M. Simileanu*, Automated optoelectronic device for qualitative analysis of the artwork surfaces using the LIF technique, *Rom. Reports Phys.*, Vol. **60**, Iss. 4, 2008.
- [17] *J. Striber, L.M. Angheluță, R. Rădvan, M. Simileanu, R. Savastru*, Optoelectronic device and process for the qualitative analysis of art objects surfaces by LIF technique, Romanian patent RO125259-B1 deposited on 14.05.2008.
- [18] *J. Striber, R. Rădvan, L. M. Angheluță*, Laser spectroscopy methods for an 18th century grisaille painting investigation, *J. Optoelectron. Adv. Mater.*, Vol. **11**, Iss. 11, 2009.
- [19] *L. Angheluță, A. Moldovan, R. Rădvan*, The teleoperation of a LIF scanning device, *Univ. Politeh. Buchar. Sci. Bull.-Ser. A-Appl. Math. Phys.*, Vol. **73**, Iss. 4, 2011.
- [20] *L.M. Angheluță, A.S. Moldovan, D.V. Ene, R. Rădvan, R. Savastru*, Internet remote operated complex system for investigating works of art by using laser-induced fluorescence, Romanian patent RO127589-A2 deposited on 23.11.2010.
- [21] *R. Rădvan, D.V. Ene, L. Ratoiu, L.M. Angheluță*, Optoelectronic device and process for measurement and qualitative analysis of interior surfaces of archaeological artworks using the LIF technique, Romanian patent RO129317-A2 deposited on 13.09.2012.
- [22] ***, Metodologie analitică inovatoare pentru identificarea in-situ și maparea în timp real a lianților organici utilizați în pictura murală antică (artMAP) (Innovative analytical methodology for in-situ identification and real-time mapping of organic binders used in ancient mural painting), Proiect experimental demonstrativ PN-III-P2-2.1-PED-2021-3576. <https://artmap.inoe.ro/>
- [23] *E.A. Campo*, Selection of Polymeric Materials: How to Select Design Properties from Different Standards, William Andrew, Norwich, NY, USA, 2008.
- [24] *O.T. Türkan, E. Çetin*, Evaluating Combination of Solvent-Based Recycling and Mechanical Recycling of ABS Materials for Mitigating Plastic Pollution and Promoting Environmental Consciousness, *Orclever Proc. Res. Dev.*, Vol. **3**, Iss. 1, 2023, DOI: 10.56038/oprd.v3i1.410.
- [25] *M.R. Khosravani, J. Schüürmann, F. Berto, T. Reinicke*, On the Post-Processing of 3D- Printed ABS Parts, *Polymers*, Vol. **13**, Iss. 10, 2021, DOI: 10.3390/polym13101559.
- [26] *L.W. McKeen*, Permeability Properties of Plastics and Elastomers, 4th Edition, William Andrew Pub., Oxford, 2016.
- [27] *Z. Golubović, I. Danilov, B. Bojović, L. Petrov, A. Sedmak, Ž. Mišković, N. Mitrović*, A Comprehensive Mechanical Examination of ABS and ABS-like Polymers Additively Manufactured by Material Extrusion and Vat Photopolymerization Processes., *Polymers*, Vol. **15**, Iss. 21, 2023, DOI: 10.3390/polym15214197.